

# WET HYDRANT W2

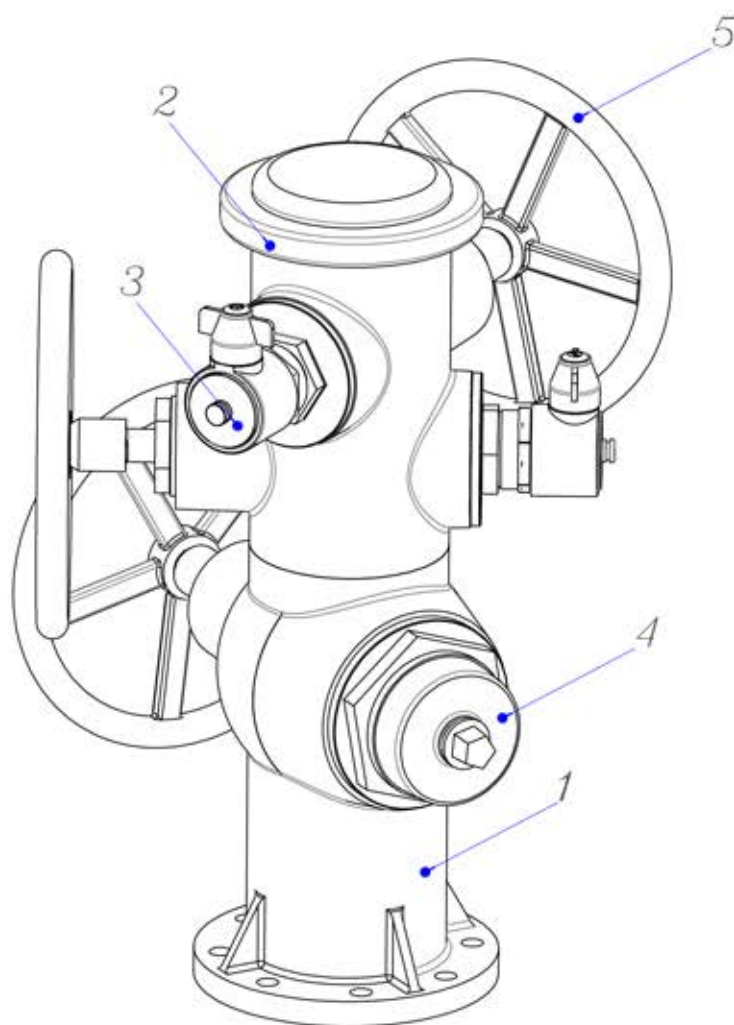

NO.	Part Name:	Material:
1	6"Lower Body	D.Cast Iron
2	6"Upeer Body	D.Cast Iron
3	Outlet 2 1/2"	Bronz
4	Pumper 4"	Bronz
5	Hand Wheel	Cast Iron

NOTE: HYDRANT MODEL:TR-PH-W2

Date	Design	Drawn	Checked	REV.
Part name: <b>TOTAL</b>		Drawing No: <b>PH-W1-01</b>		
Material: <b>AS SIDE CHART</b>		Project:		



I.T.E

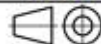

TOL: DIN-7168m

Size: **A4**

Scale: —

Sheet: **1 of 1**

QTY. :