

## WATER MONITOR MODEL: TR-MW2

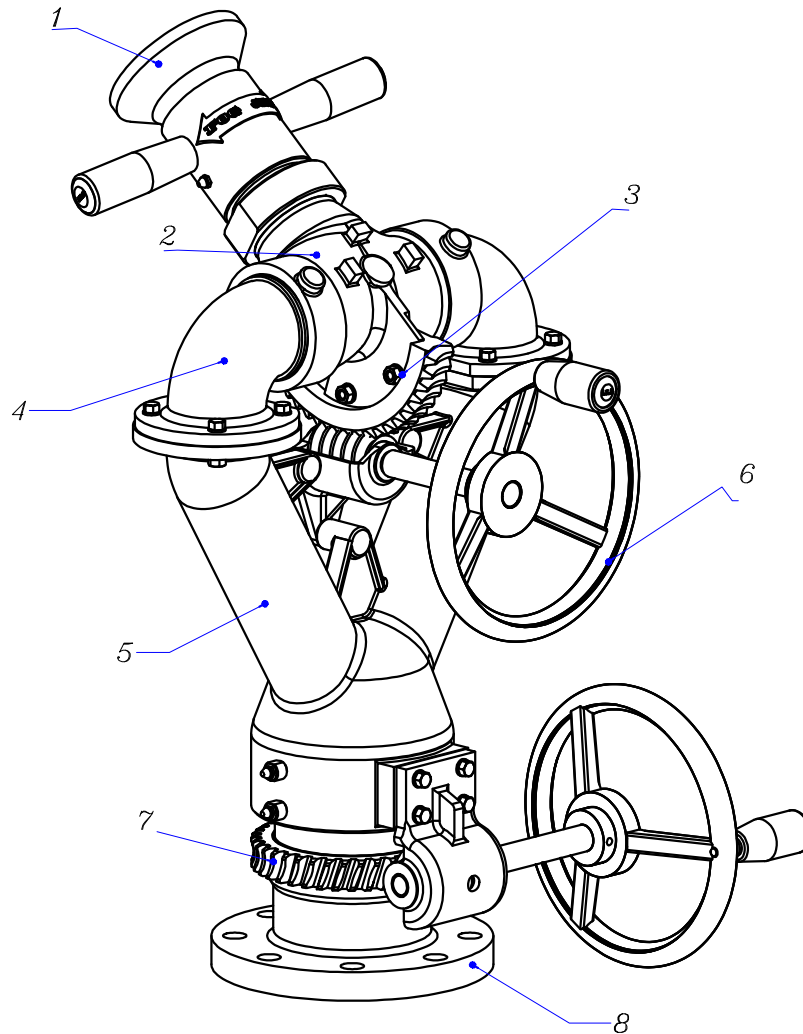



No	Part name	Material
1	NOZZLE NM1	AL
2	TRIODE	GUNMETAL
3	UPPER HELICOID GEAR	GUNMETAL
4	ELBOW	GUNMETAL
5	MAIN BODY	GUNMETAL
6	HAND WHEEL	ALUMINIUM
7	LOWER HELICOID GEAR	GUNMETAL
8	INLET FLANGE 4" #150-F.F	GUNMETAL

### TECHNICAL MONITOR :

-20° TO 80° VERTICAL	
360° HORIZONTAL	
TEST PRESSURE	21 Barg
MAX WORKING PRESSURE	15 Barg
NORMAL PRESSURE	7-10 Barg

NOTE: WATER MONITOR MODEL: TR-MW2

					 <b>I.T.E</b>  TOL: DIN-7168m Size: A4 Scale:
<i>Date</i>	<i>Design</i>	<i>Drawn</i>	<i>Checked</i>	<i>REV.</i>	Sheet: 1 Of 1
Part Name: Total		Drawing No: MW2-001			QTY. :12
Material: As above chart					